

# Installation Instructions for 8001 & 8010: Small Block / Big Block Chevy Mid Mount Alternator Kit

Read All of the Instructions Before Beginning the Installation

## Parts List:

1. Billet Alternator Bracket
2. 3-Billet Aluminum Hex Spacers
3. 3-Stainless Steel 3/8-16 X 1 1/4 Studs
4. 2-Stainless Steel 3/8-16 X 3/4 Cap Screws
5. 1-Stainless Steel 3/8-16 X 2 3/4 Cap Screw
6. 1-Stainless Steel 5/16-18 X 1 Cap Screw

## Mounting Instructions:

1. **Note:** Bracket kit to be used with standard GM alternator and a 2 or 3 groove stock type long water pump crank pulley. Kit is designed to be used with a CSI/CSR, Meziere, or Proform electric water pump.
2. Before installation remove alternator and any mounting brackets if so equipped.
3. Remove two water pump mounting bolts on the passenger side of the engine.
4. Once this is done replace bolts with two of the 3/8-16 X 1 1/4 studs. Studs will not screw all the way down and should stick out showing about half the thread. **Note:** It might be necessary to use some Loctite to keep studs from loosening.
5. After water pump studs are in place there should be one 3/8-16 X 1 1/4 stud remaining. This will be screwed into the front of the cylinder head at the hole closest to the top of the head. Remember to only screw stud about half way down. (**NOTE:** On some early big block Chevy s, the accessory holes in the heads are larger-7/16 hole. If this is the case a 3/8-16 Heli-Coil must be installed).
6. Now that all studs are in place screw the two longer hex spacers to the water pump studs and the shorter hex spacer to the cylinder head. The two hex spacers mounted to the water pump will hold that end of the pump in place. The cylinder head hex spacer will just tighten to the head. **Note:** It might be necessary to use some Loctite on the ends of the studs to keep spacers from coming loose.
7. Once studs and spacers are in place you are ready to mount your bracket. Mount bracket to the two water pump spacers using two 3/8-16 X 3/4 long cap screws.
8. After the bracket is mounted on the water pump spacers place the swing portion of the alternator between the back of the bracket and the cylinder head spacer, and mount using the 3/8-16 X 2 3/4 long cap screw.
9. Now that your alternator is mounted you must replace the belt to the alternator and set your tension. Once the belt is in place secure the alternator at the lower mounting location using the 5/16-18 X 1 cap screw. **Note:** be sure to check pulley alignment and not to over tighten belt.

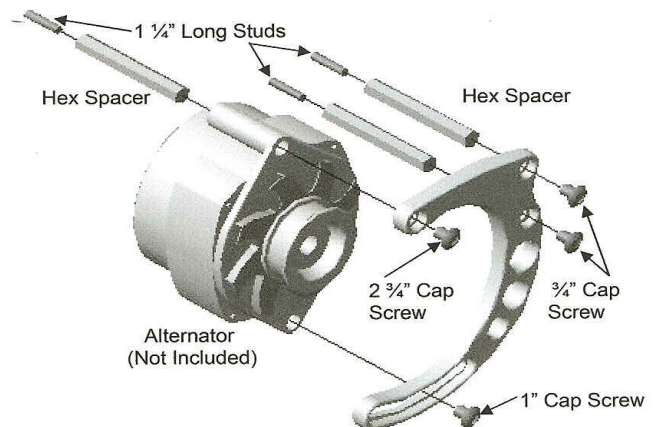

301-420-2727 speedunlimited.com